

product brief

spring 2022

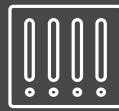

4
Intellimix

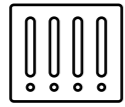

10
litt



16
iXm



24
PUC2

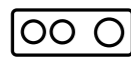

28
m!ka

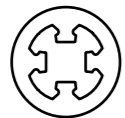

As media products become more complex, we focus on intuitive solutions. Making your work a little easier and your environment a little more elegant - that's Yellowtec's goal!

Thanks to our intimate knowledge of the media industry and its needs, our designers and engineers are able to work skillfully through every stage of product development. We know better than anyone that the purpose of innovation is to make user experience easier. Take a closer look at our products and see how innovation drives our product development.

Yellowtec commits to highest quality standards. Nearly all our products are manufactured in Germany. Premium materials and exclusive German craftsmanship make our products stand out.



reddot design award
winner 2017



Four G-Touch Faders® guide your fingers through a well shaped groove and offer various fader modes. Experience exceptional precision.



The new and free Octopus firmware extends Intellimix to a full-blown 8-channel device. Channel inputs are intuitively organized in two layer. Simply swap between them by hitting a button.



Intellimix is compatible with the whole package of AoIP solutions. The optional X64 extension board allows to run multichannel AES67, Lifewire+, RAVENNA, MADI, NMOS and ST2110. Easily integrate Intellimix.



An intuitive user interface secures quick and reliable news production even when time is of the essence. Individual profiles and setups ease and fasten your work.



ADAT and SDI connectivity perfectly support the handling of audio for video. With the intuitive G-Touch® faders there's no need to turn away from your monitor.



Intellimix fits any desktop. Lightweight, with low power consumption and without thermal load, Intellimix fully complies all the challenges of broadcast vehicles.

Intellimix

Desktop Mixer

Completely familiar, entirely revolutionary. We designed Intellimix to stimulate your creativity and to simplify your daily work. Enjoy a whole new perspective of intelligent audio mixing.



1



2

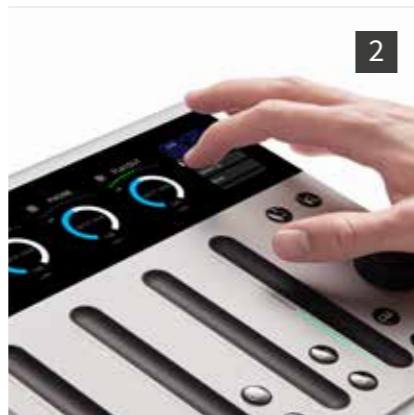

Intellimix Control Unit

- Display Light hi-res color TFT transreflective widescreen with 250Cd/m2
- Display Sensor 5-finger touch sensor, gesture ready
- Faders 4 - G-Touch® 120mm faders with multifunction position indicators
- Keys 12 - illuminated sealed hard keys (dual color)
- Chassis Solid aluminum body with integrated SD-card reader
- Channels 8 - simultaneous channels displayed in 2 layers

1 Intellimix Pro Desktop Mixer YT2200

8-channel device
 X64 AoIP integrated as standard
 advanced admin + setting options
 unlimited amount of user profiles

Intellimix Pro content of delivery:
 1x Intellimix Pro Base Unit incl. X64 AoIP
 1x Intellimix Control Unit
 1x permanently installed cable to connect both units
 1x PSU
 1x microfiber cloth
 4x self adhesive rubber feet

2 Intellimix Focus Desktop Mixer YT2202

4-channel device
 X64 available add-on option
 further simplified setting options
 only one user profile

Intellimix Focus content of delivery:
 1x Intellimix Focus Base Unit
 1x Intellimix Control Unit
 1x permanently installed cable to connect both units
 1x PSU
 1x microfiber cloth
 4x self adhesive rubber feet

Intellimix Multi I/O Loom analog YT2330

analog out 5+6 (XLR-M),
 GPO 1-4 (D-Sub),
 headphone out (Jack Socket)

Intellimix Multi I/O Loom digital YT2331

AES in 2+3 (XLR-F),
 AES out 2+3 (XLR-M),
 GPI 1+2 (D-Sub)



Intellimix Pro

Intellimix Focus

Channels	8 simultaneous channels displayed in 2 layers. Fader link of up to 4 groups of max 8 channels available	4 simultaneous channels displayed in 1 layer
Channel Display Control	Fab Four parameters of your choice are displayed	1 parameter of your choice is displayed
Madi	optional as an internal extension 56 or 64 MADI input channels, 56 or 64 MADI output channels YT2300 MADI port, single mode STP YT2301 MADI port, multimode STP	-/-
X64 AoIP	as standard	as option: X64 AoIP extension
APC Ports	4 RJ45 powered Ethernet unlocked 1 for Control Unit, 3 for extensions	1 RJ45 powered Ethernet unlocked for Control Unit
External Extensions	YT2313 Analog I/O Module YT2311 Digital I/O Module YT2310 Multi I/O Box YT2314 Mic/HP Module YT2312 Dual SDI Embedder/ De-embedder	-/-
Program Buses	2	1
Aux Buses	4	1
Mix Minus Buses	4 - including 2 b-line controls	1 - with b-line control
Dynamics	fully adjustable	auto-gain compressor (ON/OFF) only ratio / gain adjustable
EQ	fully parametric	high: Shelving mid: Bell low: Shelving
User Administration	Admin Mode available unlimited amount of user profiles	No Admin Mode only 1 user profile



Intellimix Base Unit 19“

Inputs*	Mic/Line Inputs Line Inputs analog Line Inputs digital ADAT-S/PDIF USB AoIP (DANTE)	2 - balanced, with selectable sensitivity -77 dBu ... +18 dBu 2 - XLR, balanced, max. +24 dBu 2 - RCA, unbalanced, max. +24 dBu 3 - AES3/EBU with sample rate converters 1 - optical, selectable ADAT 8-channel input or S/PDIF stereo input with sample rate converter 1 - 16 mono/8 stereo inputs based on PUC2 technology 1 - RJ45 4 mono channels come as standard
Outputs*	Line Outputs analog Headphone Line Output digital ADAT-S/PDIF USB AoIP (DANTE)	4 - XLR, balanced, max. 24 dBu 2 - RCA, unbalanced, max. 24 dBu 2 - Stereo 3 - AES3/EBU with sample rate converters 1 - optical, selectable S/PDIF stereo output with sample rate converter or ADAT 8-channel output 1 - 16 mono/8 stereo outputs based on PUC2 technology 1 - RJ45 4 mono outputs on board
Others*	GPI/GPOs APC Extension-Ports Ember+	2 - GPI via optocoupler 4 - GPO from PhotoMOS relay 4 - RJ45 powered Ethernet for extensions 1 - RJ45

Options*

Internal Extensions*	X64 Extension (YT2305) (for Intellimix Focus only) (comes as standard with Intellimix Pro)	- AES67 64 channels in + 64 channels out (8 streams) - nDNS / SDP / RAVENNA Advertisement - Livewire+ Advertisement + GPIO Control - SAP / Dante Advertisement - NMOS Advertisement - SMPTE ST2110 ready
	MADI Port, single mode STP	- 56 or 64 MADI input channels + 56 or 64 MADI output channels (YT2300)
	MADI port, multimodeSTP	- 56 or 64 MADI input channels + 56 or 64 MADI output channels (YT2301)
External Extensions*	Multi I/O Box (YT2310)	- 2 mic/line inputs, 2 headphone out, 8 analog line inputs + outputs, 3 AES3/EBU inputs, 2 AES3/EBU outputs, 1SDIF input + output, 2 USB Audio IF, 10 GPI + GPO, 2 ACI
	Analog I/O Module (YT2313)	- 18/24 dBu, 4 analog line inputs + outputs, 4 GPI + 4 GPO isolated
	Digital I/O Module (YT2311)	- 4 AES3/EBU/SDIF inputs with sample rate converters, 4 AES3/EBU/SDIF outputs
	Mic/HP Module (YT 2314)	- 4 mic/line inputs with remote preamp 0...63dB, 18dBu max. input level, phantom power 48V indiv. switchable, 4 stereo headphone amp outputs , 4 general purpose inputs, 8 general purpose outputs, isolated, 4 analog control inputs
	Dual SDI Embedder/De-embedder (YT2312)	- 2 3G/HD/SD SDI De-embedders, 2 HD/SD SDI Embedders, each: in, 2x loop through, out BNC connectors for 2 audio groups, 8 channels, SRCs selectable audio groups 1/2 or 3/4, 4 GPI, isolated, 4 GPO, isolated

*channelcount in mono

*The listed logos (from left to right + top to bottom) are registered trademarks by Audio Engineering Society, The Telos Alliance, Audio Engineering Society, Audinate Pty. Ltd., LAWO AG, Society of Motion Picture and Television Engineers® and Advanced Media Workflow Association, Inc.



litt

Signaling Device

litt brings convenience and flexibility. Programmable light and flash patterns, ultra-bright CleanVision® LED technology, sleek design and an easy assembly system coalesce to create a new class of signaling.



reddot design award
winner 2013



Enjoy distinctive colors and a powerful light characterized by CleanVision® technology. litt's homogenous colors raise awareness even in the most demanding surroundings.



Thanks to rugged bayonets, segments can be customized. Multiple combinations and a variety of lighting patterns assure a high degree of flexibility.



Each segment has its own Flash-RAM. Connect litt to your PC via USB and set up each segment's pattern individually. The Lighthouse® software is free.



Engineered using high-quality materials including anodized aluminum and polyamide, litt provides both strength and longevity.



litt is fully compatible with Yellowtec's m!ka Mounting System for microphones and monitors. WW



There are many ways to integrate litt into different environments. Easily attach litt to any kind of machine.



litt

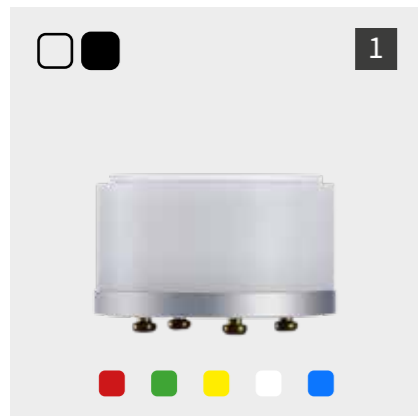
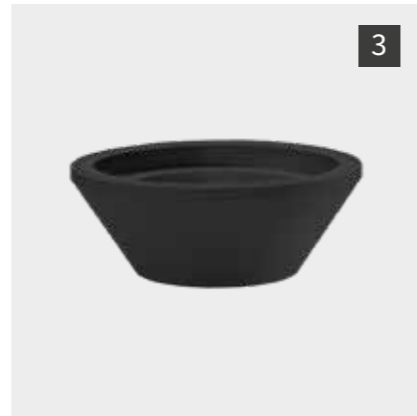

1 litt 50/22 Color Segment
ø 51mm
height 27mm

YT9201 red, aluminum
YT9202 green, aluminum
YT9203 yellow, aluminum
YT9204 white, aluminum
YT9205 blue, aluminum

YT9801 red, black
YT9802 green, black
YT9803 yellow, black
YT9804 white, black
YT9805 blue, black

2 litt 50/35 Color Segment
ø 51mm
height 40mm

YT9301 red, aluminum
YT9302 green, aluminum
YT9303 yellow, aluminum
YT9304 white, aluminum
YT9305 blue, aluminum

YT9901 red, black
YT9902 green, black
YT9903 yellow, black
YT9904 white, black
YT9905 blue, black

3 litt Spoiler
ø top 51mm
ø bottom 29mm
height 18mm

YT9550 aluminum
YT9592 black

4 litt 50/37 Sound Segment
ø 51mm
height 42mm

YT9210 aluminium

litt

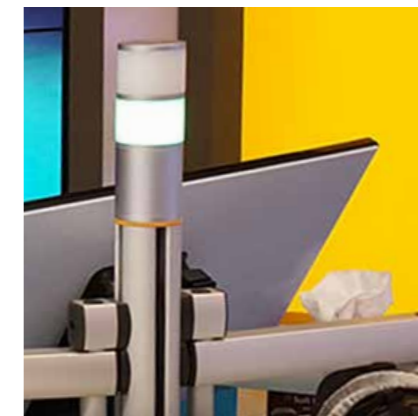

1 litt 50 Base Controller Wall Mount

includes litt Universal Mounting Kit
ø 51mm
height 45mm
for up to 5 litt Segments

YT9101 aluminum

2 litt System Cable
8 wires
color coded

YT9600 per meter
YT9601 50m drum
YT9603 100m drum

3 litt 50 Socket
YT9555

to be used with a litt Mounting Flange

4 litt 50 Base Controller

includes litt Universal Mounting Kit
ø 51mm
height 54mm
for up to 5 litt Segments

YT9100 aluminum
YT9700 black



litt



1 litt Riser

YT9500 S 120mm aluminum
YT9501 M 240mm aluminum
YT9502 L 360mm aluminum
YT9503 per meter aluminum

YT9570 S 120mm black
YT9571 M 240mm black
YT9572 L 360mm black

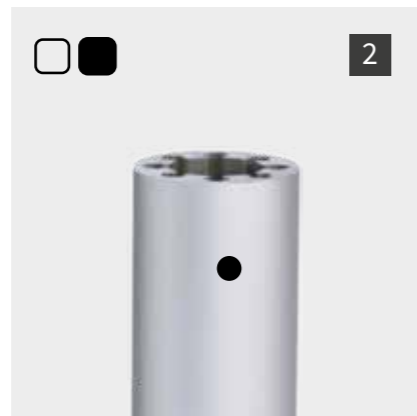

2 litt Ceiling Suspension

YT9510 S 120mm aluminum for ceiling mount
YT9511 M 240mm aluminum for ceiling mount
YT9512 L 360mm aluminum for ceiling mount

YT9580 S 120mm black for ceiling mount
YT9581 M 240mm black for ceiling mount
YT9582 L 360mm black for ceiling mount

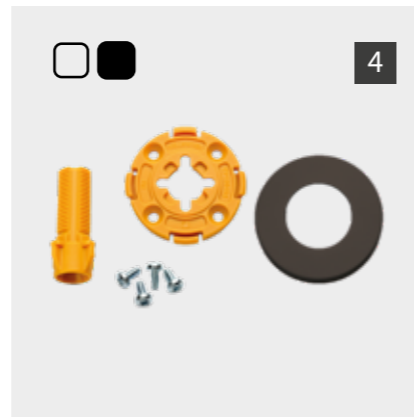

3 litt 3/8" Base Controller Mounting Set

ø51mm
for mic stands
YT9560 aluminum

4 litt Mounting Flange

YT9520 aluminum
YT9590 black

5 litt Universal Mounting Kit (UMK)

YT9401

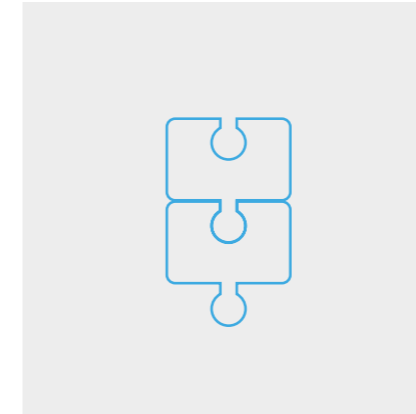

Connection Data

Power Supply Voltage	9V...24V
Power Rqmts	Base Controller: 0.5 W Color Segment: max 2.5W

Cable Data

Braid	mm2 0.2...0.5 AWG 26...20
Solid Wire	mm2 0.14...0.5 ø 0.45...0.8 AWG 26...20

Base Controller Connections

Label	Description	Signal
Chassis	Housing Potential, Connection to protective Earth recommended	PE
Ground	Minus Connection of Supply Voltage, stable Power Supply Unit	0V
+9-24V	Plus Connection of Supply Voltage, stable Power Supply Unit	+9V...24 V
Red	Control Input for red Color Segment, operable practically without loading	+3...24 V
Yellow	Control Input for yellow Color Segment, operable practically without loading	+3...24 V
Green	Control Input for green Color Segment, operable practically without loading	+3...24 V
Blue	Control Input for blue Color Segment, operable practically without loading	+3...24 V
White	Control Input for white Color Segment, operable practically without loading	+3...24 V

litt





iXm

Recording Microphone

Capture the best voice recording ever with perfect audio levels at the push of a button. With iXm, it's never been easier to record pristine audio on location.



The onboard LEA Level Energy Arbitration Technology guarantees perfectly leveled recordings - no matter the surroundings.



Change recording characteristics within seconds by simply switching mic heads. You get whatever pickup pattern is best for your given surroundings.



SD Card Readers for USB-C and Lightning allow you to transfer files to mobile devices in the fastest way possible. Share recording files directly to your mobile device!



Doing interviews is a demanding task. With iXm you get a reliable device. Be assured to achieve great sound and perfectly leveled recordings at the first try.



For content creators it's all about their content. With the brand-new iXm Podcaster you get an extremely easy-to-use device meeting the needs of every podcaster.



Use iXm to get best-in-class audio for your video recordings. Simply record your audio with iXm and afterwards do audio/video sync to get extraordinary sound.



iXm Podcaster Recording Mic

To meet the wishes of the podcasting community, we rethought the iXm and come up with an additional version: iXm Podcaster – a tool affordable for every ambitious podcaster who is longing for the iXm Recording Mic’s sound quality.



	iXm Podcaster	iXm Recording Mic
Color	blue	dark grey
Power Source	single power source: battery compartment for 3x AA batteries	dual power source: - battery compartment for 3x AA batteries - internal rechargeable li-ion battery
Recording Characteristics	as standard: dynamic cardioid iXm PRO Line Mic Head does not support any other mic heads	comes with a mic head of your choice: switch heads anytime to change characteristics: - dynamic iXm PRO Line Heads by Yellowtec: cardioid / supercardioid - electret iXm PREMIUM Line Heads by beyerdynamic: omni / cardioid / supercardioid

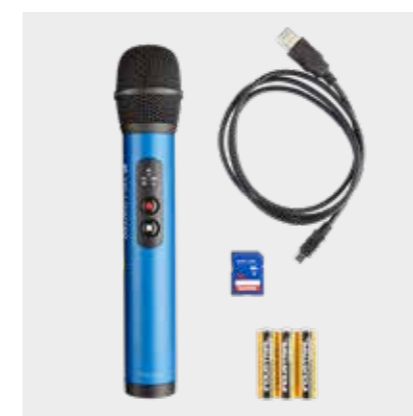

iXm Podcaster
YT5080

comes with dynamic cardioid
iXm PRO Head only

no switchable mic heads
no built-in battery

all other features are equivalent to
the iXm Recording Mic’s feature set

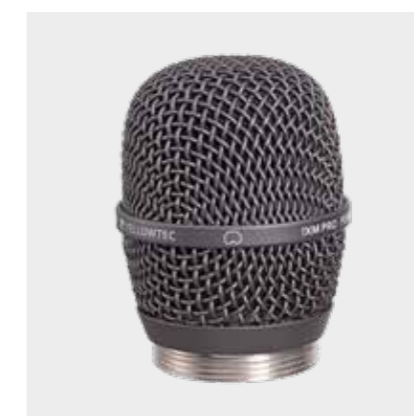

**iXm PRO Head
cardioid**
Yellowtec
dynamic

Sensitivity: 1.8mV/Pa +/-4dB
Impedance: 3000ohm +/-30%
Dimensions: 72mm x ø50mm
Weight: 139g

content of delivery:
- iXm Podcaster Recorder
- iXm PRO Mic Head cardioid
- 16GB SD Card
- USB Cable
- iXm Briefing Book
- iXm Configuration Software



iXm

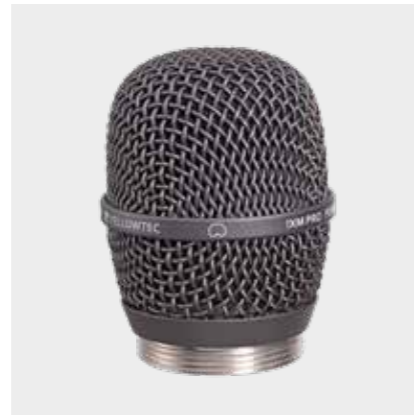
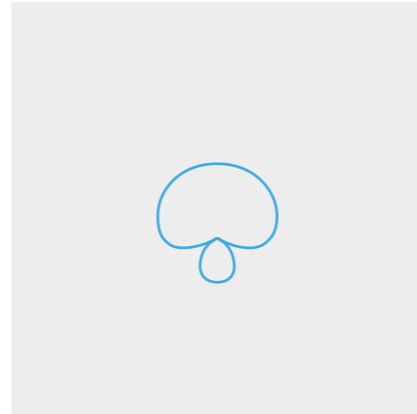
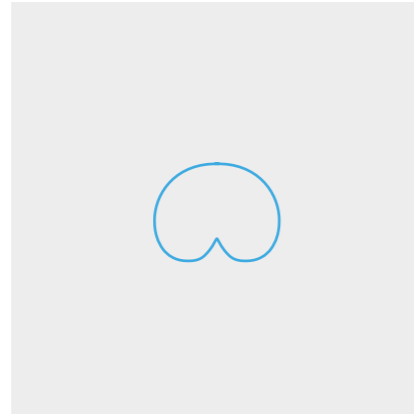

iXm PRO Head cardioid
Yellowtec
dynamic

Sensitivity: 1.8mV/Pa +/-4dB
Impedance: 300Ohm +/-30%
Dimensions 72mm x ø50mm
Weight: 139g

iXm PRO Head supercardioid
Yellowtec
dynamic

Sensitivity: 1.8mV/Pa +/-4dB
Impedance: 300Ohm +/-30%
Dimensions 72mm x ø50mm
Weight: 139g

YT5050 iXm Recorder with PRO Head cardioid (Yellowtec)

YT5051 iXm PRO Head cardioid (Yellowtec)

YT5060 iXm Recorder with PRO Head supercardioid (Yellowtec)

YT5061 iXm PRO Head supercardioid (Yellowtec)

iXm

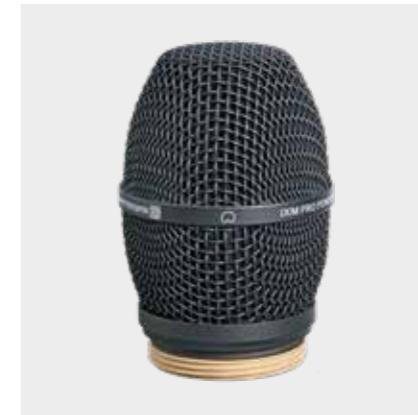
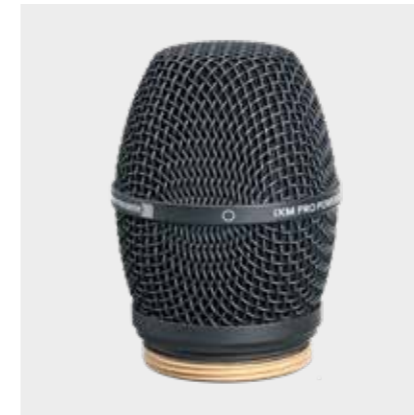
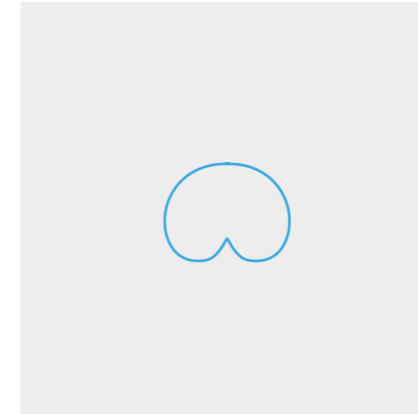
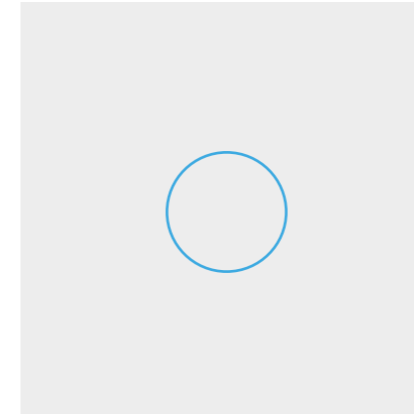

iXm PREMIUM Head omni-directional
beyerdynamic
electret

Sensitivity: 6mV/Pa +/-4dB
Impedance: 200Ohm
Dimensions 72mm x ø48mm
Weight: 92g

iXm PREMIUM Head cardioid
beyerdynamic
electret

Sensitivity: 6mV/Pa +/-4dB
Impedance: 200Ohm
Dimensions 72mm x ø48mm
Weight: 92g

iXm PREMIUM Head supercardioid
beyerdynamic
electret

Sensitivity: 6mV/Pa +/-4dB
Impedance: 200Ohm
Dimensions 72mm x ø48mm
Weight: 92g

YT5010 iXm Recorder with PREMIUM Head omni-directional (beyerdynamic)

YT5011 iXm PREMIUM Head omni-directional (beyerdynamic)

YT5020 iXm Recorder with PREMIUM Head cardioid (beyerdynamic)

YT5021 iXm PREMIUM Head cardioid (beyerdynamic)

YT5030 iXm Recorder with PREMIUM Head supercardioid (beyerdynamic)

YT5031 iXm PREMIUM Head supercardioid (beyerdynamic)



iXm Recording Mic

Mic Input	Frequency Response Input referred Noise THD+N Gain High-Pass Filter Capsule Filter	20 Hz - 20 kHz +/- 1,5 dB @ 44.1 + 48 kHz -105 dB (@60dB Gain) 0.01% @ 20 dB GainTHD+N Up to 60dB Gain 12 dB/oct. @ 80, 100, 120, 150, 180, 200 Hz (switchable) 3 times parametric filters autoselected by capsule type recognition
Line Input	Line Input Level (balanced) Line Input Level (unbalanced) THD+N	-20 dBu ... 6 dBu @FS -20 dBu ... 0 dBu @FS 0.01% or -78 dB @ -3 dBFS
Line Output	Line Output Level (balanced) Line Output Level (unbalanced) Frequency Response THD+N	-20 dBu ... 6 dBu @FS -20 dBu ... 0 dBu @FS 20 Hz - 20 kHz +/- 1 dB @ 44.1 and 48 kHz 0,01% or -78 dB @ -3 dBFS
Digital Parameters	Sampling Frequency Bit Resolution Audio Formats Bit Rates MPEG mono Bit Rates MPEG dual-channel Number of Channels	48 kHz, 44.1 kHz, 32 kHz 16 Bit Linear PCM, MPEG 1 Layer 2 128, 160, 192 kbps 256, 320, 384 kbps 1 mono or 2 dual-channel (mono)
Headphone Out	Minimum Impedance Output Power	16 Ohm 40 mW @ 16 Ohm
Memory	Memory Card File System File Format Data Connection Recording Time	SD or SDHC Memory Card up to 16 GB FAT16 FAT32 (SD-CARD) BWF, WAV, MP2, Support of BWF Header Information (Version 0) USB 2.0 Depends on SD-Card and File-Format Example: 2 GB = 22.75hrs @192 kbps mono
Dimensions & Weight	Total Length Recorder Diameter Recorder Weight Recorder	193mm 36mm 263g

1



2

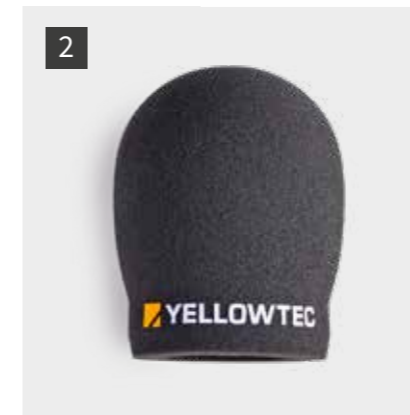

4



6



3



5



7



1 iXm Pouch
YT5101

2 iXm Windscreen
YT5102

3 iXm Clamp
YT5103
with 3/8" & 5/8"

4 iXm Boomer
YT5150

5 iXm SD Card Reader
USB-C
YT5166

6 iXm SD Card Reader
Lightning
YT5165

7 iXm Hard Case
YT5150

iXm Bundles

- content of delivery:
- iXm Recorder with iXm Mic Head
 - iXm Pouch
 - iXm Windscreen
 - USB-C SD Card Reader
 - Lightning SD Card Reader

- YT5210 with omni PREMIUM Head
- YT5220 with cardioid PREMIUM Head
- YT5230 with supercardioid PREMIUM Head

- YT5250 with cardioid PRO Head
- YT5260 with supercardioid PRO Head



PUC2

HD USB Audio Interface

As a compact two-channel interface, PUC2 combines simple setup and clever modular design. Various versions provide different analog panels. Just the way you need it.



Connect PUC2 to your PC or Mac via USB. There's no need to open your devices or to install any drivers. Installation effort kept as low as possible! Simply plug'n'play!



As a high-definition preamp, PUC2 delivers audio with up to 192kHz and 24bit. What you get is high-end sound quality at its best.



With its integrated LEA Level Energy Arbitration Rechnology, PUC2 Mic LEA ensures pristine audio quality with best-in-class leveling for your mic input signal.



PUC2 comes as a high-definition audio converter with balanced audio. As a soundcard it exceeds the demands of any professional audio workstation.



Playout systems require reliability and great sound quality at the same time. Without depending on a separate power supply unit, PUC2 delivers.



To record simply insert PUC2 between analog audio equipment and your PC. Via USB it gets you high-definition digitized and PC-ready audio files.



1



2

All PUC2 versions have the same weight & dimensions:

length: 185 mm
width: 127 mm
height: 41,5 mm
weight: approx. 600g



4



3

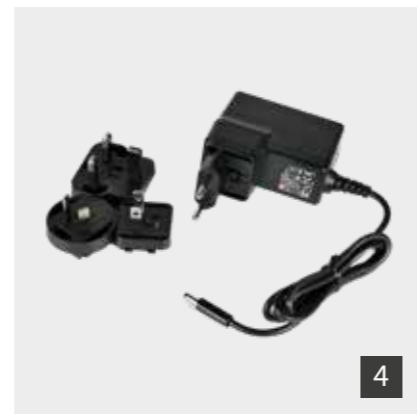

4

1 PUC2 Line
with AES3 I/O, analog Line I/O on XLR and H/P

YT4210 PUC2 Line
German Levels
0dbFS = +15dBu
(+6 dBu / 9 dB Headroom)

YT4211 PUC2 Line
International Levels
0dbFS = +18dBu
(+4 dBu / 14 dB Headroom)

2 PUC2 Lite
YT4240
purely digital version
with AES3 I/O

3 PUC2 Mic LEA
YT4221
real-time LEA Level Energy Arbitration Technology for perfect audio levels

comes without microphone to be used with your favored mic

4 PUC2 Wall Charger
YT4291
for all PUC2 versions

		PUC2 Lite	PUC2 Line	PUC2 Mic LEA
Power		< 1000 mA via USB	< 1000 mA via dual USB	< 1000 mA via dual USB + PSU
Clocking	Jitter	< 15 mUI Peak	< 15 mUI Peak	< 15 mUI Peak
	Frequency Accuracy	+/- 10 ppm	+/- 10 ppm	+/- 10 ppm
Input Selection		AES3 only	Automatic with AES Detection	Automatic with AES Detection
Digital Input	Format	AES 3 + SPDF/DIF	AES 3 + SPDF/DIF	AES 3 + SPDF/DIF
	Connectors	XLR	XLR	XLR
	Sampling Rate	44.1 kHz, 48 kHz, 88.2 kHz, 96 kHz, 176.4 kHz, 192 kHz	44.1 kHz, 48 kHz, 88.2 kHz, 96 kHz, 176.4 kHz, 192 kHz	44.1 kHz, 48 kHz, 88.2 kHz, 96 kHz, 176.4 kHz, 192 kHz
	Bit Depth	24 Bit	24 Bit	24 Bit
Digital Output	Format	AES 3 + SPDF/DIF	AES 3 + SPDF/DIF	AES 3 + SPDF/DIF
	Connectors	XLR	XLR	XLR
	Sampling Rate	44.1 kHz, 48 kHz, 88.2 kHz, 96 kHz, 176.4 kHz, 192 kHz	44.1 kHz, 48 kHz, 88.2 kHz, 96 kHz, 176.4 kHz, 192 kHz	44.1 kHz, 48 kHz, 88.2 kHz, 96 kHz, 176.4 kHz, 192 kHz
	Bit Depth	24 Bit	24 Bit	24 Bit
Analog Input	Electronically balanced		@ Full Scale	
	Input Level 1 (switchable)		+6dBu / max +15dBu	-∞ ... +18dBu
	Input Level 2 (switchable)		+4dBu / max +15dBu	
	Input Level 3 (switchable)		+5dBu / max +15dBu	
	Impedance		18 kOhm typ.	Mic typ 1.2 kOhm Live typ 10 kOhm
Analog Output	Electronically balanced		@ Full Scale	Not balanced
	Output Level 1 (switchable)		+6dBu / max +15dBu	Adjustable Volume
	Output Level 2 (switchable)		+4dBu / max +15dBu	
	Output Level 3 (switchable)		+5dBu / max +15dBu	
	Impedance		40 kOhm typ.	< 16 Ohm, Headphones with up to 600 Ohm can be used
USB	Connector	USB 2.0 Type B	USB 2.0 Type B	USB 2.0 Type B
	Driver	The USB driver uses the Windows Media Encoder (WME) by Microsoft Inc. and ASIO Driver Interface Technology by Steinberg Media Technologies GmbH. ASIO is a trademark and software of Steinberg Media Technologies GmbH. WME is a trademark and software by Microsoft Inc.		
Phantom Power (switchable)	Voltage			48 V
Headphone Output	3.5mm Jack		Fixed Volume Setting	
	6.3mm Jack			Adjustable Volume
	Impedance		< 16 Ohm	< 16 Ohm, Headphones with up to 600 Ohm can be used
Microphone Input (electronically balanced)	GAIN			0.05%
	Inout referred Noise			-127 dBu @ 150 Ohm
	Impedance			1.2 kOhm
AD/DA Converter	Dynamic		108 dB	108 dB
	THD+N ADA		-107 dB THD+N	-107 dB THD+N
	THD+N DAC		-103 dB THD+N	-103 dB THD+N
	Sampling Rate DAC		44.1 kHz, 48 kHz, 88.2 kHz, 96 kHz, 176.4 kHz, 192 kHz	44.1 kHz, 48 kHz, 88.2 kHz, 96 kHz, 176.4 kHz, 192 kHz
	Bit Depth		24 Bit	24 Bit



m!ka

Mounting System

Designed for seamless integration, the m!ka systems provides you with an elegant and powerful combination of components. Design your individual setup in the most flexible way.



Designed as a versatile system, any m!ka element is compatible with a whole range of mounting devices. Combine components according to your needs.



Individually adjust your m!ka setup to your microphone's or monitor's weight. You achieve perfect hold in any desired position.



Made of sturdy anodized aluminum, all m!ka components come as rugged premium constructions. Nearly all elements are available in aluminum and black color.



Choose m!ka Mic Arms with dual color white/red On Air indicator to signalize multiple statuses. It comes with premium CleanVision® lighting characteristics.



Thanks to QuickFix and a VESA75/100 adapter, any kind of monitor can be securely fastened to any m!ka Monitor Arm within seconds.



Choose m!ka add-ons to integrate other gear into your setup and achieve maximum flexibility just the way you need it.

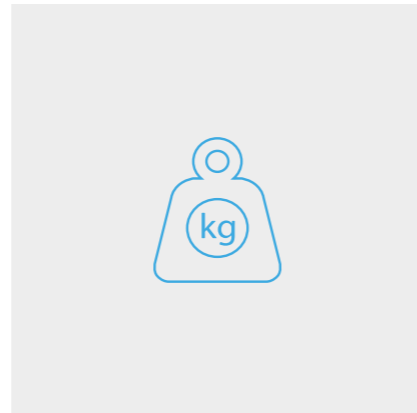

1

1 m!ka Mic Arm XS

max range 21" (53.5cm)
weight 1.98 lbs net (0.9kg)
weight 2.65 lbs gr (1.2kg)
max mic weight 3.3 lbs (1.5kg)

with open cable ends

YT3105 aluminum „on air“
YT3505 black „on air“

with installed XLR-connectors

YT3105XLR aluminum „on air“
YT3505XLR black „on air“



2

2 m!ka Mic Arm M

max range 31" (78.7cm)
weight 2.31 lbs net (1.05kg)
weight 2.31 lbs gr (1.5kg)
max mic weight 3.3 lbs (1.5kg)

with open cable ends

YT3205 aluminum „on air“
YT3605 black „on air“
YT3201 aluminum
YT3601 black

with installed XLR-connectors

YT3205XLR aluminum „on air“
YT3605XLR black „on air“
YT3201XLR aluminum
YT3601XLR black



3

3 m!ka Mic Arm XL

max range 42.3" (107.5cm)
weight 3.20 lbs net (1.45kg)
weight 4.63 lbs gr (2.1kg)
max mic weight 2.65 lbs (1.2kg)

with open cable ends

YT3305 aluminum „on air“
YT3705 black „on air“
YT3301 aluminum
YT3701 black

with installed XLR-connectors

YT3305XLR aluminum „on air“
YT3705XLR black „on air“
YT3301XLR aluminum
YT3701XLR black

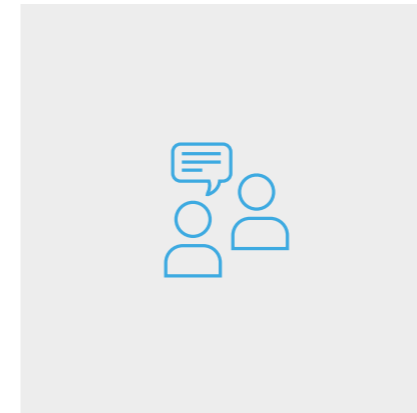

Thanks to its low profile design, the m!ka Mic Arm TV perfectly meets all the requirements of camera recordings and interviews as it keeps your face free from visual barriers.

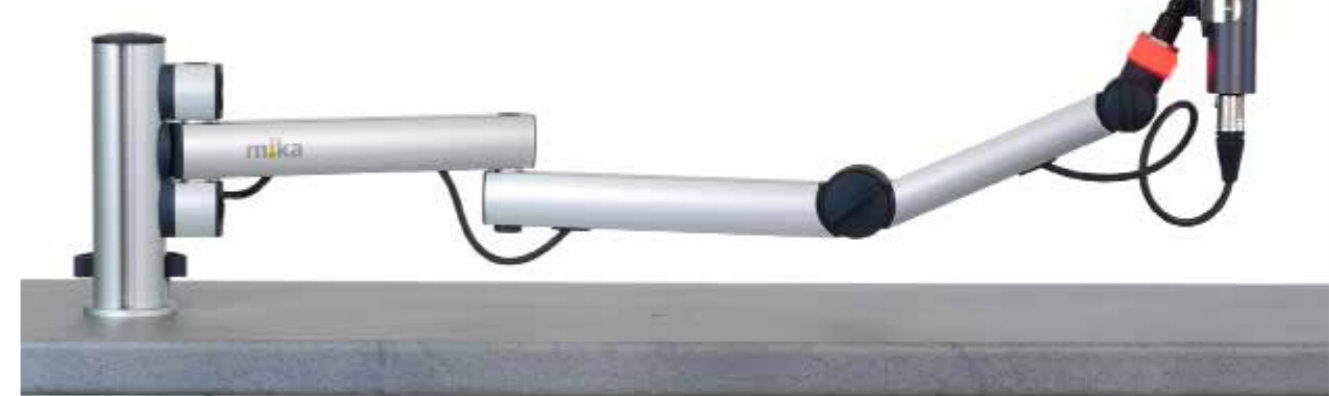

m!ka Mic Arm TV

max range 26.4" (67cm)
weight 2.31 lbs net (1.05kg)
weight 3.31 lbs gr (1.5kg)
max mic weight 4.41 lbs (1.5kg)

with open cable ends

YT3206 black
YT3207 aluminum
YT3208 black „on air“
YT3209 aluminum „on air“

with installed XLR-connectors

YT3206XLR black
YT3207XLR aluminum
YT3208XLR black „on air“
YT3209XLR aluminum „on air“

Optional XLR Mounting

Choose between m!ka Mic Arms with open cable ends or with installed XLR-connectors.

All NON On Air m!ka Mic Arms come with 3-pin XLR-connectors on both, the upper and lower end of the cable.

All m!ka Mic Arms with On Air come with 3-pin XLR-connector on the upper end of the cable. On the lower end of the cable they come with a 5-pin XLR-connector which is needed to control the redlight.

NEW!



m!ka

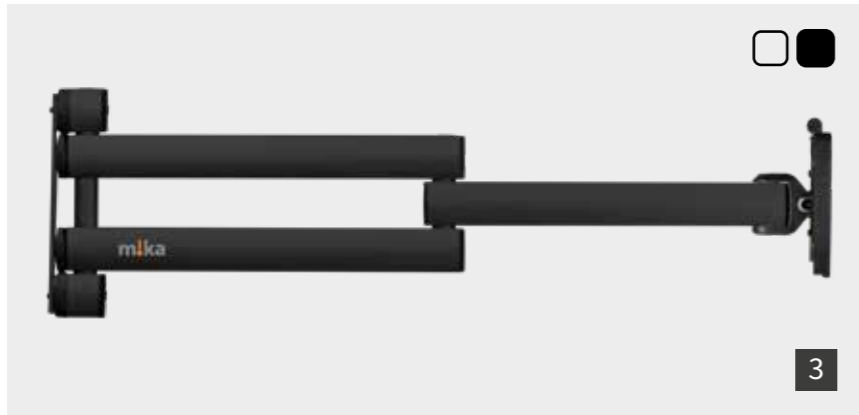
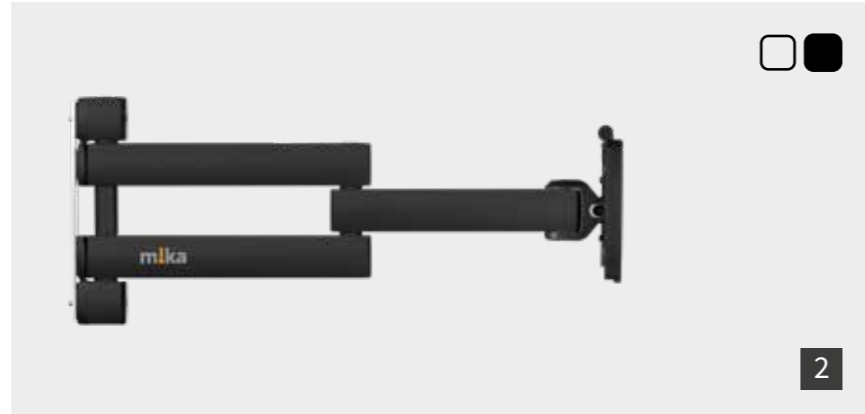

1 m!ka Monitor Arm XS
max range 4.13" (10.5cm)
max monitor weight 15kg

YT3231 aluminum
YT3631 black

2 m!ka Monitor Arm M
max range 19.89" (50.5cm)
max monitor weight 15kg

YT3230 aluminum
YT3630 black

3 m!ka Monitor Arm XL
max range 27.76" (70.5cm)
max monitor weight 10kg

YT3229 aluminum
YT3629 black

4 m!ka Pivot Monitor Adapter YT3278
adapter for monitor turn up to 90°
max monitor weight 15kg
compatible with all m!ka Monitor Arms + m!ka EasyLift Arms

5 m!ka Monitor Arm SL
(m!ka Pad-Dock not included)
max range 17.72" (45cm)
max monitor weight 10kg

YT3228 aluminum
YT3628 black

m!ka

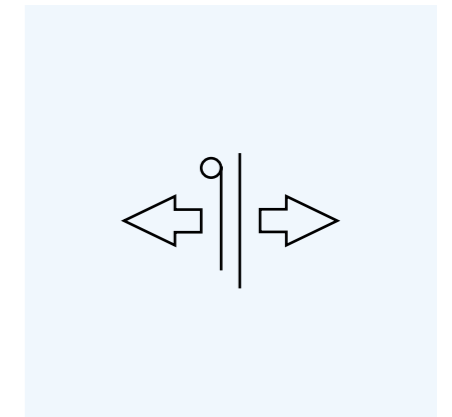

1 m!ka EasyLift S Monitor Arm
max range 14.37" (36.5cm)
max height 11" (28cm)

YT3801 aluminum for monitors with 3-8kg
YT3802 aluminum for monitors with 7-15kg

3 m!ka EasyLift M Monitor Arm
max range 20.28" (51.5cm)
max height 16" (40.5cm)

YT3811 aluminum for monitors with 3-8kg
YT3812 aluminum for monitors with 7-15kg

4 m!ka EasyLift L Monitor Arm
max range 20.28" (51.5cm)
max height 12" (30.5cm)

YT3821 aluminum for monitors with 3-8kg
YT3822 aluminum for monitors with 7-15kg

2 m!ka Twin Monitor Mount YT3279
to mount two monitors to one arm
max load capacity 15kg
for monitors with up to 30" each
compatible with all m!ka Monitor Arms + m!ka EasyLift Arms



m!ka

m!ka



NEW!

m!ka Cam Arm On Air

Enjoy more comfortable ways to integrate cameras into your m!ka setup!



camera not included

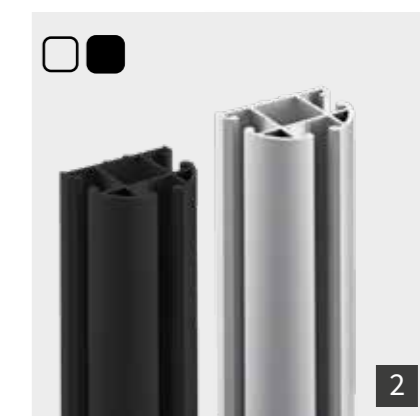
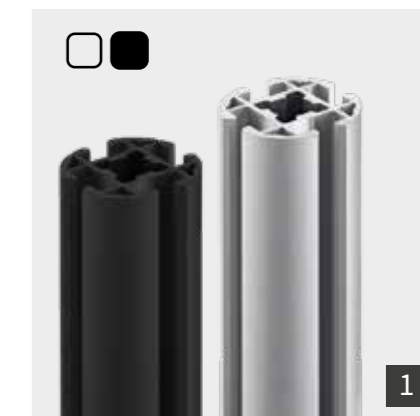

1 m!ka CamStud

ø 29mm
(matching litt Riser & litt Spoiler)
adjustable integrated ball joint
for mounting standard cameras
and web cams via 1/4" screw

YT3276 aluminum
YT3277 black

CamStud mounting options:

- attach it to any m!ka Cam Arm
- attach it to any m!ka Mic Arm
- mount directly on top of litt Riser
- mount on m!ka System Pole with the help of a litt Spoiler

2 m!ka Cam Arm OnAir

fully compatible with m!ka CamStud
no cable on the upper end of the arm
for tidy camera wiring and fast
camera arrangements

size + range equals m!ka Mic Arm M
max range 31" (78.7cm)
max camera weight 3.3 lbs (1.5kg)

open cable end

YT3920 aluminum „on air“
YT3921 black „on air“

with installed 5-pin XLR-connector

YT3920XLR aluminum „on air“
YT3921XLR black „on air“

1 m!ka System Poles

ø 51mm

aluminum

YT3235 XS 7.09" (18cm)
YT3240 S 17.5" (44.5cm)
YT3243 M 21.5" (54.5cm)
YT3241 L 33.3" (84.5cm)

black

YT3236 XS 7.09" (18cm)
YT3640 S 17.5" (44.5cm)
YT3643 M 21.5" (54.5cm)
YT3641 L 33.3" (84.5cm)

2 m!ka Wall Mount Poles

ø 51mm

aluminum

YT3260 S 17.5" (44.5cm)
YT3261 XL 35" (89cm)

black

YT3660 S 17.5" (44.5cm)
YT3661 XL 35" (89cm)

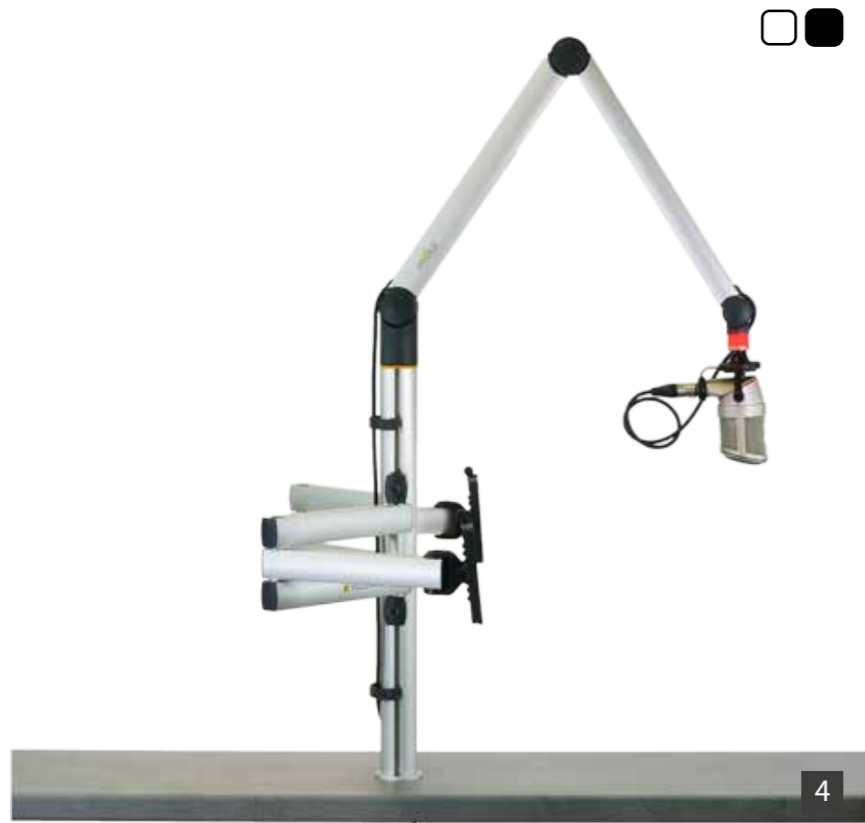

1 m!ka Set 1
Single Monitor Set
YT3410 aluminum
YT3840 black
1x Monitor Arm XS
1x System Pole M 21,5"
1x Pole Desktop Mounting Kit

4 m!ka Set 4
Dual Monitor + Single Mic Set
YT3413 aluminum
YT3843 black
2x Monitor Arm M
1x On Air Mic Arm M
1x System Pole M 21,5"
1x Pole Desktop Mounting Kit

2 m!ka Set 2
Single Monitor + Single Mic Set
YT3411 aluminum
YT3841 black
1x Monitor Arm XS
1x On Air Mic Arm M
1x System Pole M 21,5"
1x Pole Desktop Mounting Kit

5 m!ka Set 5
Triple Monitor Set
YT3414 aluminum
YT3844 black
1x Monitor Arm XS
2x Monitor Arm M
1x System Pole M 21,5"
1x Pole Desktop Mounting Kit

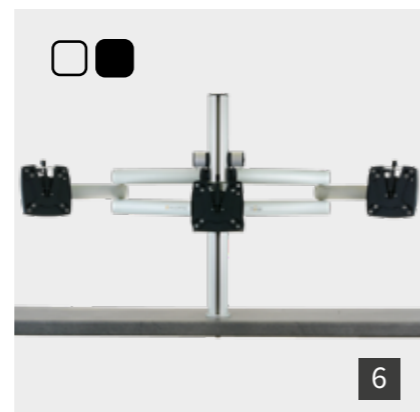
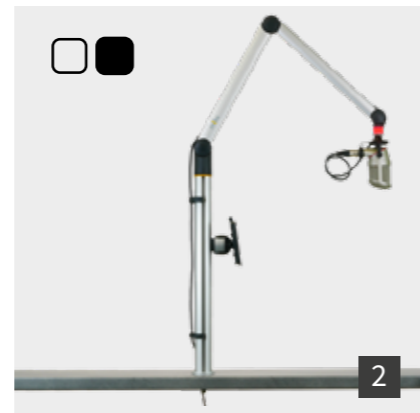

3 m!ka Set 3
Dual Monitor Set
YT3412 aluminum
YT3842 black
2x Monitor Arm M
1x System Pole M 21,5"
1x Pole Desktop Mounting Kit
for 2 monitors with up to 40" each

6 m!ka Set 6
Triple XL Monitor Set
YT3415 aluminum
YT3845 black
1x Monitor Arm XS
2x Monitor Arm XL
1x System Pole M 21,5"
1x Pole Desktop Mounting Kit

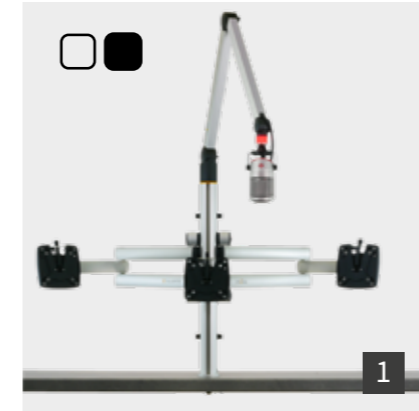

1 m!ka Set 7
Triple XL Monitor + Single Mic Set
YT3416 aluminum
YT3846 black
1x Monitor Arm XS
2x Monitor Arm XL
1x On Air Mic Arm M
1x System Pole M 21,5"
1x Pole Desktop Mounting Kit

4 m!ka Set 10
Single Monitor + Single Mic + CopyStand Set
YT3419 aluminum
YT3849 black
1x Monitor Arm M
1x Monitor Arm SL
1x Copy Stand M with QuickFix
1x On Air Mic Arm M
1x System Pole M 21,5"
1x Pole Desktop Mounting Kit

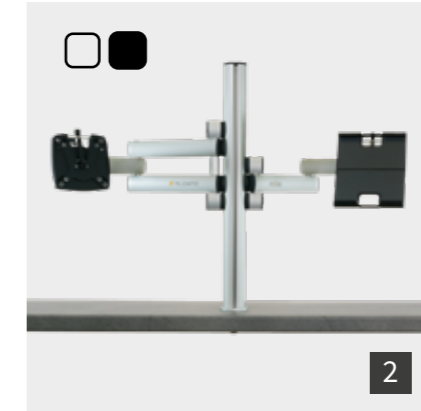

2 m!ka Set 8
Single Monitor + Pad-Dock Set
YT3417 aluminum
YT3847 black
1x Monitor Arm M
1x Monitor Arm SL
1x Pad-Dock with QuickFix
1x System Pole M 21,5"
1x Pole Desktop Mounting Kit

5 m!ka Set 11
Single Monitor + Single Mic + Pad-Dock Set
YT3420 aluminum
YT3850 black
1x Monitor Arm M
1x Monitor Arm SL
1x Pad-Dock with QuickFix
1x On Air Mic Arm M
1x System Pole M 21,5"
1x Pole Desktop Mounting Kit

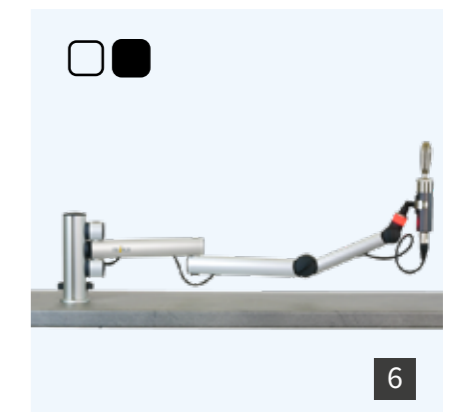
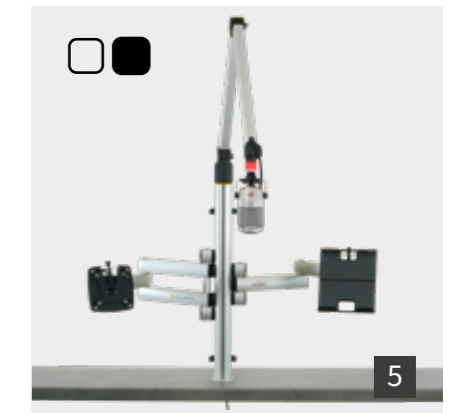

3 m!ka Set 9
Single Monitor + CopyStand Set
YT3418 aluminum
YT3848 black
1x Monitor Arm M
1x Monitor Arm SL
1x Copy Stand M with QuickFix
1x System Pole M 21,5"
1x Pole Desktop Mounting Kit

6 m!ka Set 12
Single TV Mic Set
YT3421 aluminum
YT3851 black
1x On Air Mic Arm TV
1x System Pole XS 7,09"
1x Pole Desktop Mounting Kit

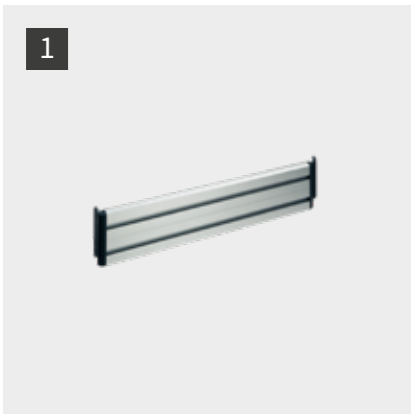
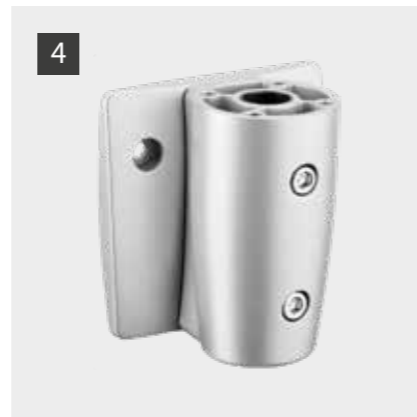
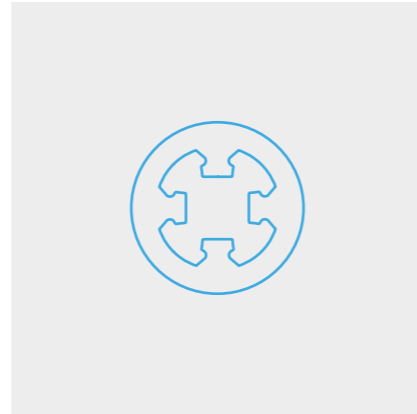

1 m!ka System Wall S

31.5" (80cm)
YT3290 aluminum



2 m!ka System Wall M

39.4" (100cm)
YT3291 aluminum



3 m!ka System Wall L

47.3" (120cm)
YT3292 aluminum

4 m!ka System Wall Adapter

YT3295 aluminum



1 m!ka Copy Stand M (A4)
with QuickFix

YT3271 aluminum
(Monitor Arm not included)



2 m!ka Copy Stand XL (A3)
with QuickFix

YT3272 aluminum
(Monitor Arm not included)

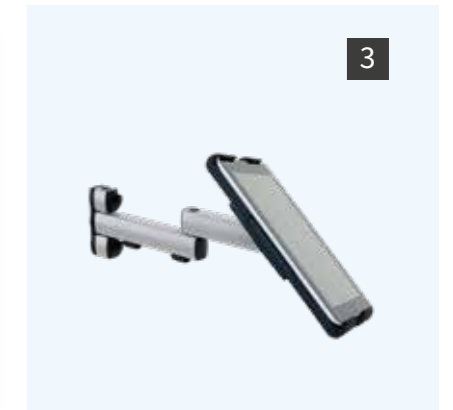

3 m!ka Pad-Dock
YT3275 with QuickFix

for tablet devices with a side length
of 160-300mm
(Monitor Arm not included)

4 Perspex Panel (A4)
YT3273

to be used with Copy Stand M
for magnetic paper fixation

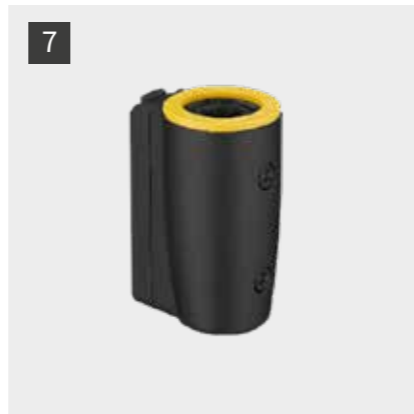
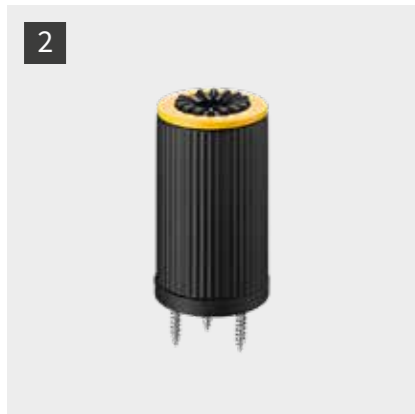
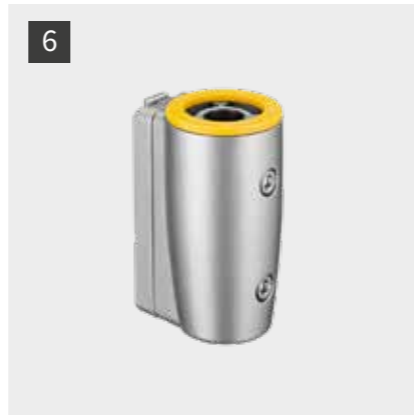
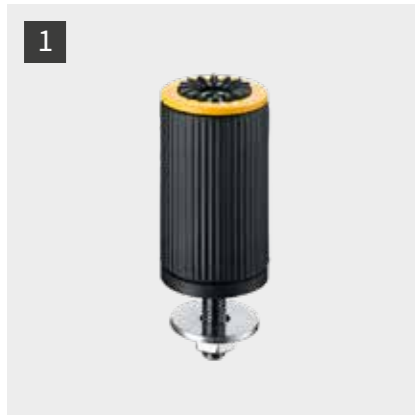

1 Table Through Mount
YT3215
max panel thickness 25mm

3 Bushing
YT3211
max panel thickness 45mm

5 Table Clamp
YT3210
panel thickness 18-74mm

2 Table Mount
YT3216
unlimited panel thickness

4 Wall Bracket
YT3214

6 Pole Adapter
YT3213 aluminum

7 Pole Adapter
YT3613 black

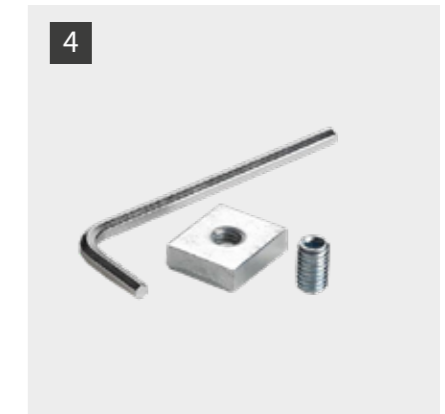
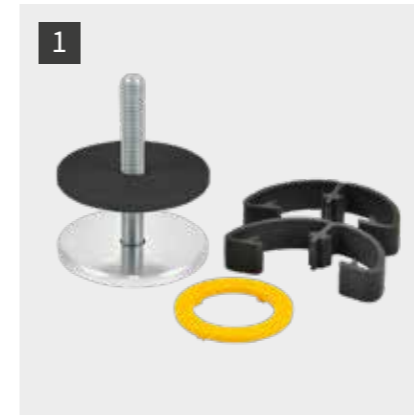
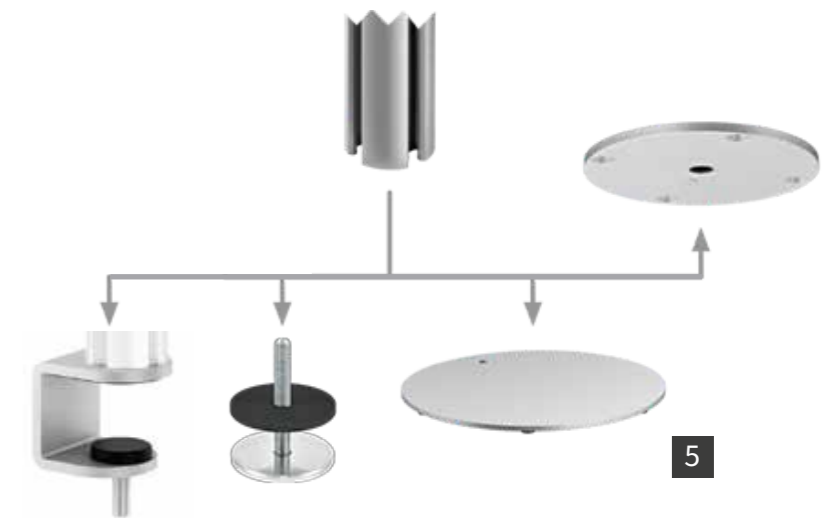

1 System Pole Desktop Mounting Kit
YT3245 dual color
max panel thickness 50mm

2 System Pole Table Clamp
(System Pole not included!)
YT3249 aluminum
panel thickness 14-40mm

3 System Pole Ceiling Mounting Kit
YT3248 aluminum

4 Pole Safety Stop
YT3222

5 Pole Table Stand
YT3217 aluminum

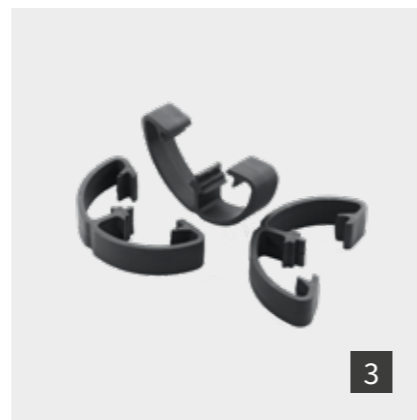

1

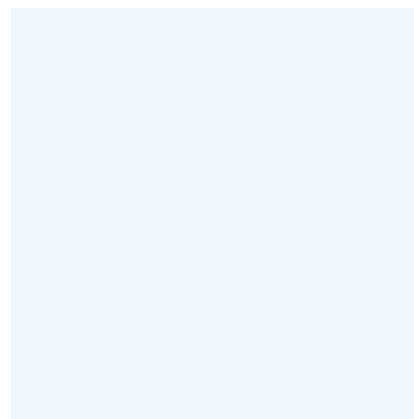

4



2



4

1 Plastic Sleeve
YT3247 Polybag (10 pcs.)

3 Cable Clamp for System Pole
YT3221 Polybag (6 pcs.)

4 Cable Clamp for Monitor Arm
YT3220 Polybag (10 pcs.)

2 Yellow Spacer
YT3246 Polybag (10 pcs.)



1

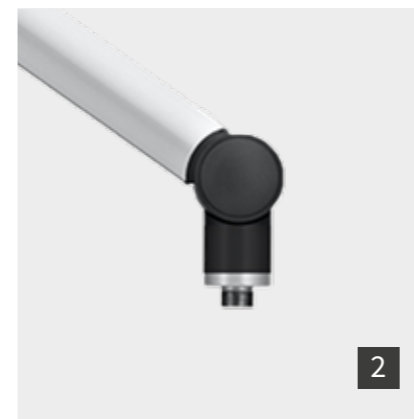

2

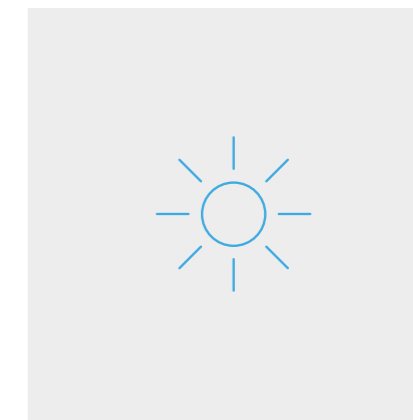
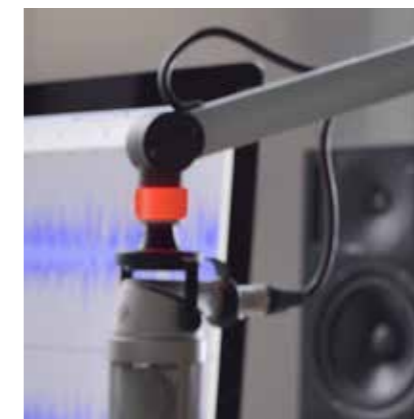

1



2

1 5/8" Mic Adapter (MKII)
YT3350 „on air“
dual color red/white

for aluminum / black Mic Arms
compatible with all previously
released arms

2 5/8" Mic Adapter (MKII)
YT3351 without indicator

for aluminum / black Mic Arms
compatible with all previously
released arms

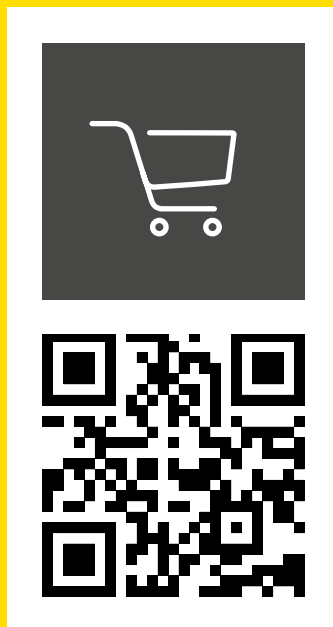

shop.yellowtec.com