

Data Sheet TMR7 Smart

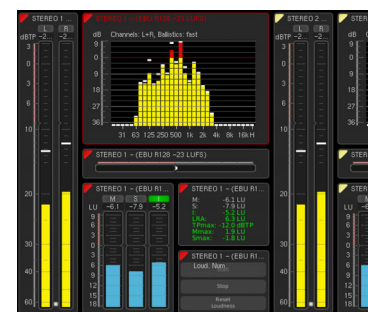

TMR7 Smart



Touch Screen ▪ **AES3 I/O via XLR** ▪ **Highly Flexible Screen-Layout** ▪ **2 x 2-ch. PPM/True Peak** ▪ **2 Audio Vectorscopes**
EBU, ITU, ATSC, ARIB, OP-59, AGCOM, CALM Loudness ▪ **LRA** ▪ **SPL-Meter** ▪ **RTA** ▪ **Moving Coil** ▪ **Loudness Chart**

The four audio inputs provided by the two AES3 XLR ports are flexibly configurable for mono or stereo sources, providing separate instruments for each source. This allows e. g. in radio broadcast the parallel monitoring of the on-air signal and a separate source.

Beside the AES3 interfaces the GPIO interface for overall control offers even more functional options for flexible integration of TMR7 Smart into individual studio environments.

Graphical User Interface

The graphical user interface used in the TMR7 Smart is controlled simply by using your finger. Instruments can be scaled, randomly positioned and combined for optimized use of available screen space. Multiple instruments of the same type, assigned to different input channels and configurations, can be displayed simultaneously. A comprehensive on-screen help feature supports the user to make setup changes with ease.

Software

With the integrated Smart software package, TMR7 Smart is fully equipped and ready for use. Its comprehensive set of frequently used instruments provides all relevant loudness and audio metering tools to meet the demands of a wide variety of applications.

Gefördert durch:



aufgrund eines Beschlusses
des Deutschen Bundestages

Hardware

Configuration

- TMR7 Smart in a sturdy table-top frame with movable table-stand and power supply.
- 7" touch screen 16 : 9 TFT (800 x 480 pixel)
- 4-channel audio interfaces (2 x AES3 inputs via XLR-F and 2 x AES3 outputs via XLR-M)
- Connectors for Ethernet, 2 x USB 2.0, GPIO, 24 V DC
- Integrated Smart software package
- Highly flexible screen layout options with scalable instruments

Main Unit with Interfaces



Software

Smart Software Package

With the integrated Smart software package, TMR7 Smart is fully equipped. It provides a wide range of RTW's approved loudness and audio metering tools to meet the demands of a wide variety of applications. Beside the signal processing and the control functions this software includes the following instruments:



PPM instrument for up to 2 x 2 channels with digital scales (0 to -60 dB, +3 to -60 dB TruePeak, DIN5, Nordic, British Ila and IIb), Peak-Hold, Peak-Memory, Over indicator, numerical display.



Moving Coil instrument with PPM display (British), VU display, Loudness display, and combined PPM and Loudness display (BBC mode).



Loudness Sum instrument for displaying the summed loudness values M, S, and I of a loudness measurement acc. to EBU R128, ITU BS.1770-3/1771-1, ARIB, ATSC A/85, OP-59, AGCOM, CALM on bargraphs. Additional SPL meter.



Loudness Num instrument for the numerical display of all relevant values of a Loudness measurement: M, S, I, LRA, TPmax, Mmax, Smax.



LRA instrument (Loudness-Range) with MagicLRA mode for a graphical representation of loudness variances with additional display of the I value.



Loudness Chart instrument for displaying and analyzing the course of a loudness measurement directly on TMR7Smart's display.



2-ch. Audio Vectorscope for displaying the phase relationship between a selectable channel pair (Lissajous display). Two entities with 2 channels each are possible (Dual mode).



Stereo Correlator for displaying the phase relationship between the two channels of a stereo signal and thus its mono compatibility.



RTA instrument (Real Time Analyzer) for displaying the spectral content of the selected input channel(s) using 31 or 61 filter bands. Additional HP HF band available.



AES Status monitor for displaying various parameters of AES3 digital audio signals in plain text.



Global Keyboard with definable on-screen keys for simultaneous control of defined functions in multiple instruments, and for preset recall. It also allows external control vial GP IO interface.

Dimensions

TMR7 Smart Table-top unit

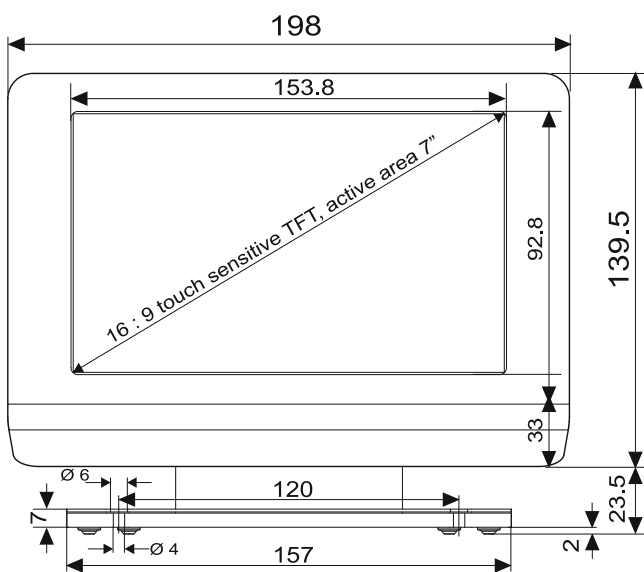

1 | Front view (dimensions in mm)

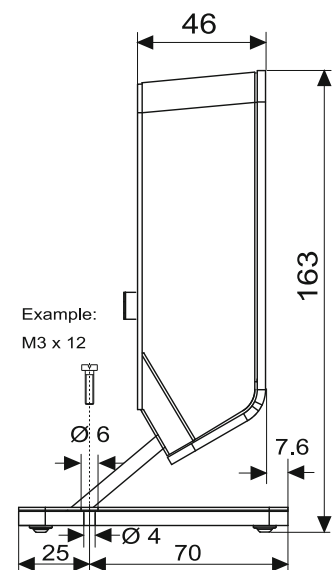

2 | Side view (dimensions in mm)

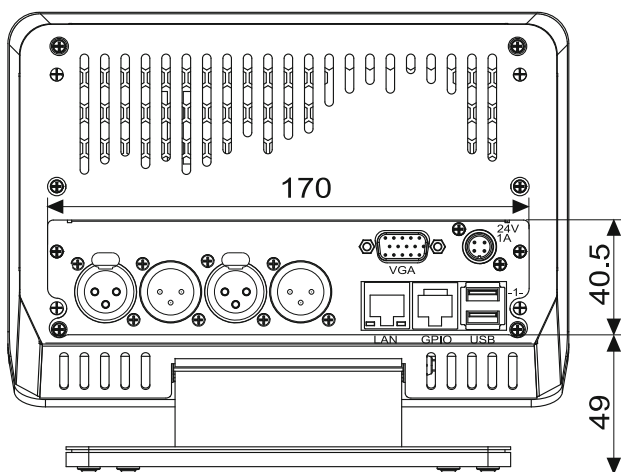

3 | Rear view (dimensions in mm)

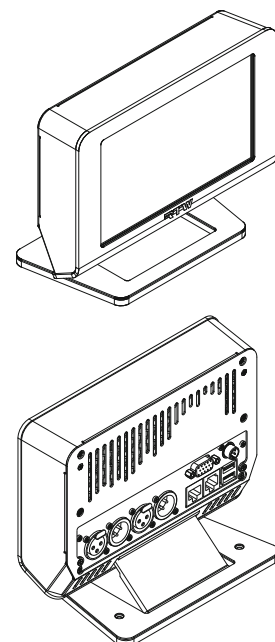

Connection

Connectors



ATTENTION! - For operating the TMR7Smart an adapted mains adapter is required. RTW recommends the use of the RTW wide voltage power supply 1168-R (100 - 240 V AC/24 V DC, 2.7 A). This power supply is included in the TMR7 Smart package.

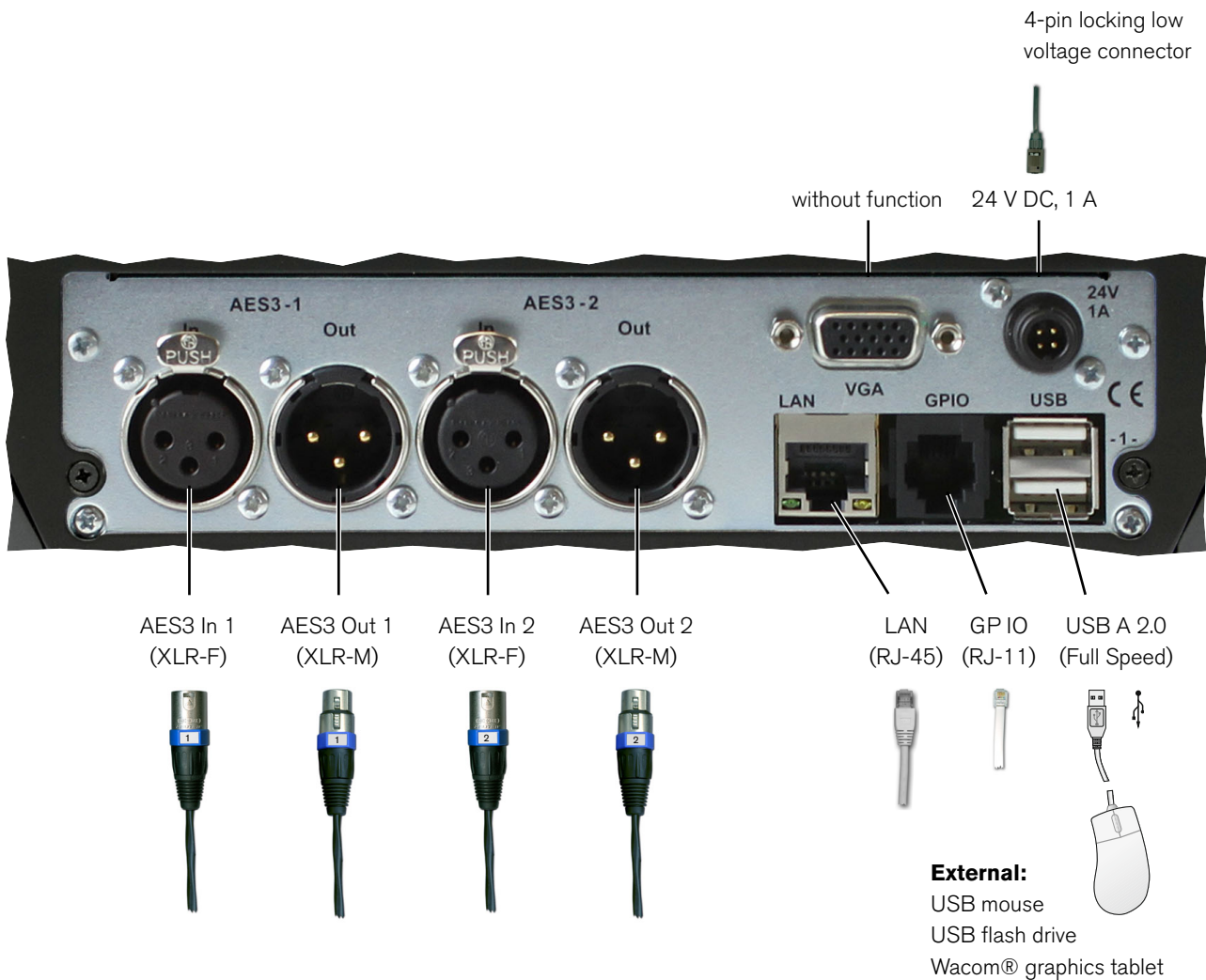

Pin Assignment

AES3 In 1, AES3 In 2 (transformer-balanced, 3-pin XLR-F)

Pin: Function:

- 1 Shield/case
- 2 +, hot
- 3 -, cold

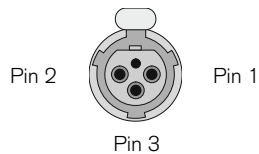

(External view of the connector)

NOTE - The AES3 inputs are permanently terminated with $110\ \Omega$.

AES3 Out 1, AES3 Out 2 (transformer-balanced, 3-pin XLR-M)

Pin: Function:

- 1 Shield/case
- 2 +, hot
- 3 -, cold

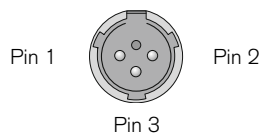

(External view of the connector)

24 V - 1 A (4-pin locking low voltage, type Binder 710)

Pin: Function:

- 1 +24 V DC
- 2 +24 V DC
- 3 0 V
- 4 0 V

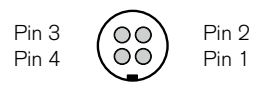

(External view of the connector)

NOTE - An external overcurrent protective device (2 A max.) shall be installed when using an external 24 V DC power supply!

LAN

RJ-45 standard network connector (10/100 Mbit)

GPIO (RJ-11 6P6C socket)

External control of functions and presets recall as defined in the Global Keyboard menu. The inputs defined as „active low“ have to be switched against 0 V (Pin 1).

Pin: Function:

- 1 GND
- 2 - 6 Function acc. to definition in the menu



(External view of the connector)

Block diagram of the GPIO interface

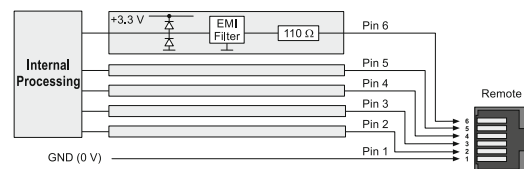

USB-A

2 Full Speed USB 2.0 interfaces for connecting USB flash drives (for updates, presets, et. al.), external mouse or Wacom® graphics tablet

Specifications

System

General

Power requirements:	+24 V DC (external 2 A max. overcurrent protective device shall be installed!)
Current drain:	1 A nominal, 2.5 A power-up current (10 µsec.)
Power dissipation:	approx. 8,5 W (w/o SDI), approx. 11 W (with SDI)
Display:	7" TFT touch screen 16 : 9 (800 x 480 pixel)
Connectors:	1 x 4-pin locking low voltage connector type Binder 710 (DC) 2 x USB A; USB 2.0 Full Speed connectors for: <ul style="list-style-type: none"> ▪ USB flash drives (preset export and import, software updates) ▪ external computer mouse for operating ▪ external Wacom® graphics tablet 1 x GPIO (RJ-11-6P6C) for defined functions or preset recall 1 x LAN (RJ-45) 2 x XLR-F (2 x AES3 In) 2 x XLR-M (2 x AES3 Out)
Dimensions (W x H x D):	198 x 139,5 (163) x 46 (95) mm (with table-stand)
Weight:	approx. 2.7 kg (without mains adapter)
Operating temperature:	+5° to +40° C

Functions

- Operation with one finger (touch sensitive display) or a computer mouse
- Instruments can be scaled and freely positioned
- Multiformat 4-ch. PPM (2-ch. Stereo, 2 x 2-ch. Stereo, single ch.)
- Loudness-Meter: ITU-R BS.1770-3/1771-1, EBU R128, ATSC A/85, ARIB, OP-59, AGCOM, CALM
- Loudness Chart instrument
- Loudness Test Time Control
- Loudness Range instrument (LRA)
- SPL meter
- Moving Coil (BR, VU, Loudness, BBC mode)
- Stereo Correlator
- 1/3- and 1/6-octave spectrum analyzer
- 2-channel Audio Vectorscope (2 instances)
- AES3 status monitor
- Numerical displays
- Up to 5 presets can be defined

Digital Inputs

Inputs:	2 AES3 inputs (transformer balanced, 110 Ω), 2 x XLR-F connector, 3-pin
Sampling rates:	44.1, 48, 96 kHz, synchronisation to digital input signal or internal clock

Digital Outputs

Outputs:	2 AES3 outputs (input signals looped through), 2 x XLR-M connector, 3-pin
Sampling rates:	referenced to digital inputs or internal clock

Smart Software

Digital Peakmeter

Input sources:	digital via XLR audio interface (AES3)
4-channel Peakmeter:	2-ch. Stereo, 2 x 2-ch. Stereo, single channel
Display:	<ul style="list-style-type: none"> ▪ Peak level ▪ Peak hold ▪ Numerical value of the display ▪ Digital Over

Functions:

- Gain (+20 dB, +40 dB acc. to standard)
- Peak hold on/off
- Memory
- Reset

Word width:

Digital scales:

- 24 bit
- TP60: +3 .. -60 dB
- Dig60: 0 .. -60 dB
- DIN5: +5 .. -50 dB
- Nordic: +12 .. -42 dB
- BR IIa: 7 .. 1
- BR IIb: +12 .. -12 dB

Headroom/Headroom Ref: acc. to standard, adjustable in the range from 0 to -20 dB in steps of 1 dB

Operation field:

adjustable in the range from 0 to -20 dB in steps of 1 dB

Integration time (Attack):

acc. to corresponding standard or selectable: Sample, 20 ms, 10 ms, 1 ms, 0.1 ms, additional 150 ms for British scales

Gain:

+20 dB, +40 dB (acc. to standard)

High-pass filter:

Off, 5 Hz, 10 Hz, 20 Hz

Peak hold indicator:

1 s, 2 s, 4 s, 10 s, 20 s, 30 s, manual reset or off

Over indicator hold time:

1 s or manual

Over indicator PPM

- Threshold:

Full Scale, Full Scale -1LSB, Full Scale -2LSB, -0.1 dBFS, -0.5 dBFS, -1 dBFS, -2 dBFS, -3 dBFS

- Attack time:

1 to 15 samples

- Word width:

16 to 24 bit, selectable

Over indicator True Peak

- Threshold:

adjustable

Audio Vectorscope

Display mode:	2-channel
Inputs:	L/R (Stereo signal with the input channels of the selected audio group)
AGC:	fast/slow
Grid:	L/R or M/S



Specifications (continued)

AES3 Status Monitor

Display:	<ul style="list-style-type: none"> channel data are displayed as plain text, hex or binary Channel selectable Audio bit activity Hardware status
----------	--

Global Keyboard

The Global Keyboard is used for simultaneous control of defined functions in multiple instruments, and for preset recall. It also allows the external control with the integrated GP IO interface.

Gain Reduction

Display:	1 bargraph for Mono and Stereo formats, up to 4 bargraphs in multi-channel mode
Input:	Data stream via TCP/IP and LAN (ethernet) interface
Input routing:	external featured streams selectable
Marker:	adjustable threshold for the definition of upper and lower display section
Colors:	32 colors for each bargraph section

EBU R128 Loudness Mode

ITU BS.1771 Loudness Mode

ATSC A/85 Loudness Mode

ARIB Loudness Mode

OP-59 Loudness Mode

AGCOM Loudness Mode

CALM Loudness Mode

Loudness Parameters

Depending on the loudness standard being used, the options and settings listed below are fixed, reduced, or not available. Please definitely note the provided buttons and their labelling in the corresponding menus.

Display:	<ul style="list-style-type: none"> M bargraph (Momentary - summation of momentary loudness values of all channels for a short span of time) S bargraph (Short - loudness summation value of an adjustable dynamic time frame) I-Bargraph (Integrated - long term loudness value infinite or manual control) adjustable tolerance range for M, S, I for M, S, I values (labelling adjustable) for LRA, TPmax, Mmax, Smax values
Numerical display:	Loudness scale: <ul style="list-style-type: none"> EBU+9: +9 .. -18 LU EBU+18: +18 .. -36 LU EBU+9a: 14 .. -41 LUFS EBU+18a: -5 .. -59 LUFS EBU0: 0 .. -60 LUFS ITU+9: +9 .. -18 LU (Loudness Units) ITU0: 0 .. -30 LKFS ATSC0: 0 .. -60 LKFS ATSC0a: 0 .. -30 LKFS
Scales: *)	

Weighting filter:	K filter acc. to ITU BS.1770
Target Level: *)	<ul style="list-style-type: none"> -23 LUFS; adjustable from -10 LUFS to -30 LUFS in steps of 1 LUFS -24 LKFS; adjustable from -10 LKFS to -30 LKFS in steps of 1 LKFS
Time & Gate Momentary: *)	
- Integration time:	400 ms
Time & Gate Short: *)	
- Integration Time:	3 s; time window adjustable from 1 to 20 s in steps of 1 s
Time & Gate Integrated: *)	
- Silence Gate:	<ul style="list-style-type: none"> -70.0 LUFS, switchable -70.0 LKFS, switchable
- Relative Gate:	-10.0 LU, switchable
Level adjustment for the summation: *)	0.0 dB, adjustable between -3 and +3 dB in steps of 0.5 dB

*) Depending on the used loudness standard not all of the listed settings are available.

Loudness Test Time Control

Settings for operating automatic, semi-automatic or manual loudness measurements.

Start:

- Functions:	Autostart after preset load, autostart with gate, autostart with gate and autoreset, manually via keys or GPI
- Level for gate:	-70,0 LUFS/LKFS; adjustable from -85 to -10 LUFS/LKFS in steps of 0.5 LUFS/LKFS

Stop:

- Functions:	manually via keys or GPI, autostop with gate, autostop with gate and time
- Level for gate:	-70,0 LUFS/LKFS; adjustable from -85 to -10 LUFS/LKFS in steps of 0.5 LUFS/LKFS
- Time for gate:	1 s; adjustable from 1 to 15 s in steps of 1 s

Loudness Range Instrument (LRA)

Display:	Graphical display of the Loudness Range
Mode:	selectable: LRA Bar, MagicLRA, MagicLRA + I, MagicLRA + I + Num
Scale range:	selectable: 6 LU, 10 LU, 20 LU, 30 LU
LRA low range:	2 LU; adjustable from 1 to 20 LU in steps of 1 LU
Comfort zone:	4 LU; adjustable from 1 to 20 LU in steps of 1 LU
LRA high range:	depends on the selected scale range and the spread of the comfort zone
Colors:	selectable for each range

SPL Meter Mode

Display:	<ul style="list-style-type: none"> Bargraphs for each single channel (can be combined with PPM bargraphs) Summation bargraph
Reference point:	adjustable in the range from 68 dB to 88 dB in steps of 1 dB
Weighting:	Linear, A (Leq(A)), C, CCIR (Leq(M)), k
Integration time:	Fast (125 ms), Slow (1 s)



Specifications (continued)

Spectrum Analyzer (RTA)

Input sources:	selectable: single channels, Stereo pairs, depending on selected mode
Frequency range:	<ul style="list-style-type: none"> ▪ Norm: 20 Hz to 20 kHz, additional band > 20 kHz switchable ▪ LF: 5 Hz to 5 kHz
Number of bands:	<ul style="list-style-type: none"> ▪ 1/3-octave: 31 bands, filter acc. to IEC 225 class 2 ▪ 1/6-octave: 61 bands
Weighting filter:	Linear; Linear, A, C selectable
Peak hold indicator:	1 s, 2 s, 4 s, 10 s, 20 s, 30 s, manual reset or off
Measuring range:	45 dB max.
Scaling:	3, 6, 9 dB
Functions:	<ul style="list-style-type: none"> ▪ Input selection ▪ Peak hold on/off ▪ A, C weighting, Linear ▪ Integration time ▪ Set reference ▪ Scaling ▪ Frequency range ▪ Bargraph arrangement ▪ Display-Hold
Integration time (ballistics):	Impulse, Fast, Slow, Peak (10 ms)

Moving Coil Instrument

Type:	PPM (L/R), PPM (M/S), VU, Loudness, PPM + Loudness (L/R; M, S, or I), selectable
PPM:	
- Ch. arrangement:	Dual, Dual + M/S horizontal, Dual + M/S vertical, Stereo horizontal, Stereo vertical
- Scales:	<ul style="list-style-type: none"> ▪ BR IIa: 7. .1, BR IIa ext: 7. .1 ▪ BR IIb: +12. .-12 dB, BR IIb ext: +12. .-12 dB
- Integration time:	Sample (digital only), 0.1 ms, 1 ms, 10 ms, 20 ms, 150 ms
- Headroom Ref:	-10 dB; adjustable from 0 to -20 dB in steps of 1 dB
- S mode:	only available, if M/S type is selected: M3, M6
- Peak indicator:	Off, Peak, True Peak, BR Peak
- BR Peak Threshold:	6 dB, <ul style="list-style-type: none"> ▪ BR IIa: adjustable from 4 to 7 dB in steps of 1 dB ▪ BR IIb: adjustable from 0 to 12 dB in steps of 1 dB

VU:

- Ch. arrangement:	Stereo horizontal, Stereo vertical
- Scale analog:	VU (-20 to +3 dB)
- Scale digital:	VU Digital (-20 to + 3 dB)
- Lead:	0 dB, adjustable from 0 to 12 dB in steps of 1 dB
- Peak indicator:	Off, Peak, True Peak

Loudness:

- Ch. arrangement:	Dual, Stereo horizontal, Stereo vertical
- Scales:	acc. to Loudness settings
- Integration time:	acc. to standard
- Peak indicator:	Off, no selectable option available

PPM + Loudness:

- Ch. arrangement:	Dual-PPM (as described above) with additional Loudness display (BBC mode) for M, S, or I (selectable) in one instrument <ul style="list-style-type: none"> ▪ PPM: see above ▪ Loudness: +9 to -9 LU fixed (mid of scale corresponds to Target Level)
- Scales:	

Numerical display:

switchable

Loudness Chart Instrument

Functions:	<ul style="list-style-type: none"> ▪ Horizontal running bargraphs (Timeline Bars) with individual selected colors for evaluating the common quality of Loudness values TP, M, S, I ▪ Coordinate system displaying a graph with the course over time of one measured value ▪ Position of the Relative Gate switchable ▪ Adjustable time ranges ▪ Selection of time periods for analyzing ▪ Vertical Integrated bargraph switchable ▪ Adjustable tolerance levels ▪ Bargraph: Color change of a running bargraph indicates the move of its loudness value through the different sections: Normal, Operation, Headroom, Over, Invalid (depending on selected value) ▪ Chart-Graph: Course over time of the selected value with color filling acc. to the color selection for the Timeline Bars (color change), Tolerance Indicator, position of the Relative Gate
Display:	



Specifications (continued)

Colors:	<ul style="list-style-type: none"> ▪ Bargraph: Individual selectable colors (32) for Normal (bar color), Operation (Range), Headroom (TP only), TP-Over (TP only), Over (M, S, I only), Invalid (M, S, I only) ▪ Chart-Graph: Adoption of the corresponding colors of the Timeline Bars, additional selectable colors for Tolerance Indicator and Relative Gate
Time Range:	<p>Selectable timescale of the coordinate system and the Timeline Bars</p> <ul style="list-style-type: none"> ▪ Increasing or decreasing the defined timescale in steps of one unit or ten units each ▪ Stretching the measured course to the available width of the window
Timerange presets:	
- Auto stretch:	Automatical stretching of the selected timescale to the available width of the window
- Hours:	0 h; adjustable from 0 to 3 h in in steps of 1 h
- Minutes:	1 m; adjustable from 1 to 59 m in steps of 1 m
Time Select:	<ul style="list-style-type: none"> ▪ Selection of the current displayed time scale ▪ Stepwise increasing and decreasing of the selection acc. to timescale ▪ Moving the selection and magnifying its content to the available width of the window
Tolerance Levels:	
- TP Headroom:	-9.0 dB; adjustable from 0 to -20 dB in steps of 0.1 dB
- TP Operation Range:	0.0 dB; adjustable from 0 to -20 dB in steps of 0.1 dB
- M High:	+1.0 LU; M tolerance above the Target Level, adjustable from 0 to 10 LU in steps of 0.1 LU
- M Low:	-1.0 LU; M tolerance below the Target Level, adjustable from 0 to -12 LU in steps of 0.1 LU
- S High:	+1.0 LU; S tolerance above the Target Level, adjustable from 0 to 10 LU in steps of 0.1 LU
- S Low:	-1.0 LU; S tolerance below the Target Level, adjustable from 0 to -12 LU in steps of 0.1 LU
- I High:	+1.0 LU; I tolerance above the Target Level, adjustable from 0 to 10 LU in steps of 0.1 LU
- I Low:	-1.0 LU; I tolerance below the Target Level, adjustable from 0 to -12 LU in steps of 0.1 LU

Items of Delivery

TMR7 Smart:

- TMR7 Smart unit in a table-top frame
 - XLR audio interface
 - Smart software (system/4-ch. digital, PPM, True Peak, Moving Coil, Correlator, dual Audio Vectorscope, RTA, Loudness Sum, Loudness Num, Loudness Range (LRA), SPL, Chart, Global Keyboard, GPI)
 - Table-stand, mains adapter, manual
- Order no.: TMR7S**

Accessory

- Wide voltage power supply **1168-R** (100 - 240 V AC/24 V DC 2,7 A, table-top unit with corresponding mains cable for different power systems)

Overview

TouchMonitor TMR7 Smart table-top unit

- Table-top unit with easy-to-use graphical interface, high-quality 7" touch screen 16:9 TFT, integrated audio interface, Ethernet, 2 x USB, GPIO, 24 V DC, table-stand, mains adapter.
- Smart software package with precise signal processing, functions for control, comprehensive range of RTW's approved loudness and audio metering tools, and flexible display options

Order number: **TMR7S**

Audio Interfaces (I/O Options)	max. Channel Count (Hardware)	Inputs Digital (balanced)	Outputs Digital (Input signals looped through)
integrated	4-channel digital In, 4-channel digital Out	2 x XLR-F (2 x AES3 In)	2 x XLR-M (2 x AES3 Out)

Instruments (can freely be scaled and positioned)

PPM 2 x 2 channels, digital scales (Dig60, TP60, DIN5, Nordic, British Ila, British Ilb), Peak Hold, Peak Memory, Over indicator, numerical display	Moving Coil (needle instrument emulation) PPM (British), VU, Loudness, BBC mode	Loudness Sum Loudness measurement acc. to EBU R128, ITU BS.1770-3/1771-1, ARIB, ATSC A/85, OP-59, AGCOM, CALM, summed Loudness values M, S, L, SPL meter	Loudness Num Numerical display of all relevant values of a Loudness measurement: M, S, L, LRA, TPmax, Mmax, Smax	Loudness-Range (LRA) Graphical representation of loudness variances, MagicLRA mode with additional display of the L value	Loudness Chart Graphical display of the course over time of a loudness measurement for analyzing
Audio Vectorscope 2-ch. display of the phase relationship of a selectable channel pair (Lissajous display). Two entities are possible (Dual mode)	Stereo Correlator Display of the phase relationship between the two channels of a stereo signal (mono compatibility)	Real Time Analyzer (RTA) Display of the spectral content of the selected input channel(s) using 31 or 61 filter bands. Additional HP HF band available	AES Status Monitor Display of various parameters of AES3 digital audio signals in plain text	Global Keyboard Global Keyboard: simultaneous control of defined functions in multiple instruments, and for preset recall, or external control via GP I/O interface	

Dimensions:	W x H x D in mm (with table-stand)
TMR7S (table-top unit):	198 x 139.5 (163) x 46 (95)



"Gefördert vom Bundesministerium für Wirtschaft und Technologie aufgrund eines Beschlusses des Deutschen Bundestages."
 Translation: Due to a resolution of the German Parliament this project is supported by the German Federal Ministry of Economy and Technology.